

Fig 40

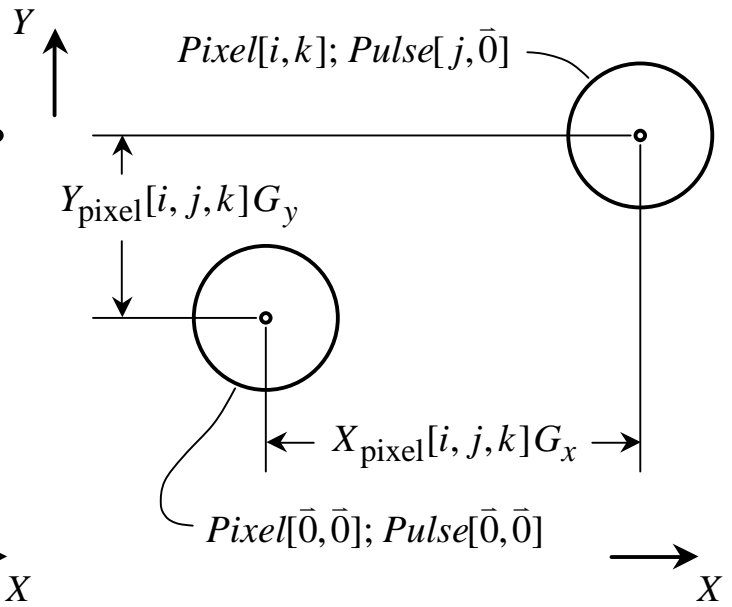

Fig 41

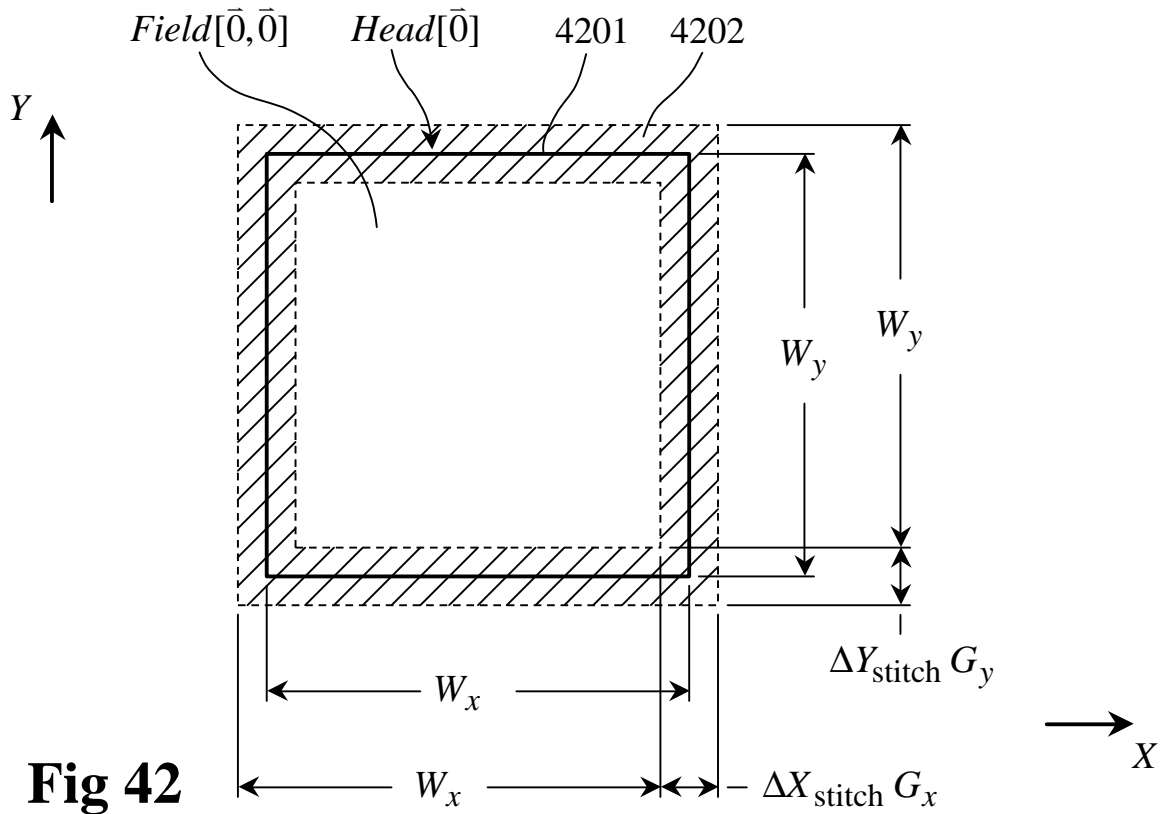

Fig 42

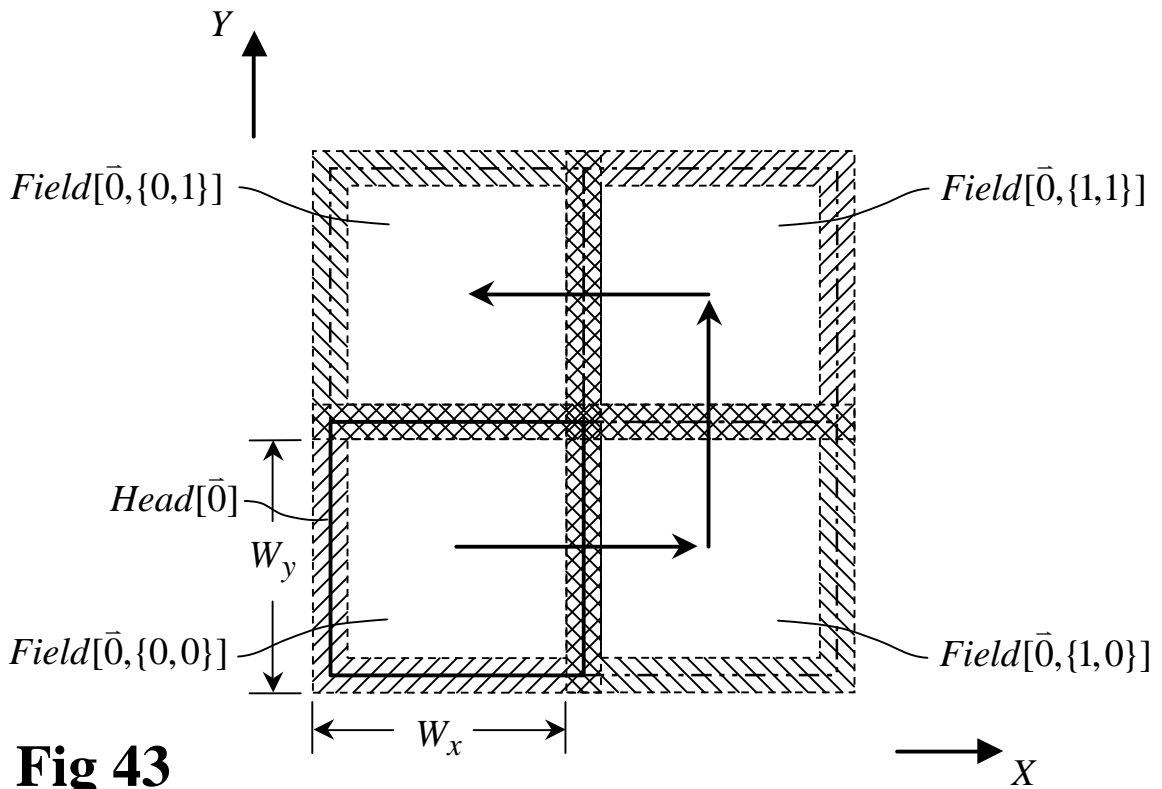

Fig 43

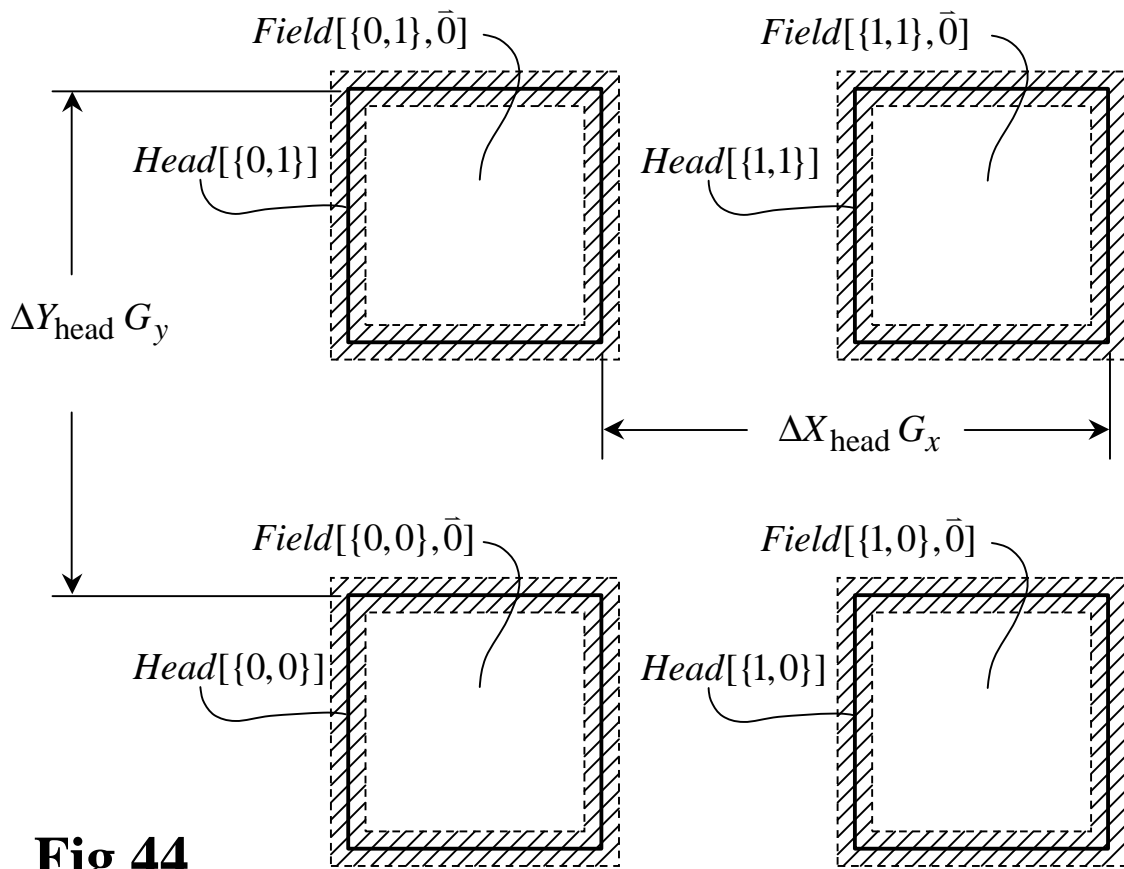

Fig 44

Scan parameters (lens scan)

$W_x = 20 \text{ mm}$	(from Eq 1.4)	$\Delta X_{\text{pulse}} = 23$	(from Eq 8.86)
$W_y = 20 \text{ mm}$	(from Eq 1.5)	$\Delta Y_{\text{line}} = 21$	(from Eq 8.87)
$G_x = 6.861 \text{ nm}$	(from Eq 8.92)	$\Delta X_{\text{scan}} = 36478$	(from Eq 8.19)
$G_y = 6.860 \text{ nm}$	(from Eq 8.97)	$\Delta Y_{\text{scan}} = 8925$	(from Eq 8.20)
$N_{\text{pulse/line}} = 1586$	(from Eq 8.23)	$\Delta X_{\text{pixel}} = 1586$	(from Eq 8.88)
$N_{\text{line/scan}} = 425$	(from Eq 8.24)	$\Delta X_{\text{offset}} = 793$	(from Eq 8.57)
$N_{\text{pulse/scan}} = 674050$	(from Eq 8.18)	$\Delta Y_{\text{pixel}} = 425$	(from Eq 8.89)
$N_{\text{pixel/row}} = 1838$	(from Eq 8.91)	$\Delta Y_{\text{period}} = 850$	(from Eq 8.59)
$N_{\text{row/head}} = 6860$	(from Eq 8.96)	$\Delta X_{\text{field}} = 2915068$	(from Eq 8.39)
$N_{\text{pixel/head}} = 12608680$	(from Eq 8.35)	$\Delta Y_{\text{field}} = 2915500$	(from Eq 8.40)
$N_{\text{row/period}} = 2$	(from Eq 8.58)	$\Delta X_{\text{stitch}} = 36478$	(from Eq 8.41)
$N_{\text{period/head}} = 3430$	(from Eq 8.36)	$\Delta Y_{\text{stitch}} = 8925$	(from Eq 8.42)
$N_{x \text{ scan}} = 2$	(from Eq 8.98)	$\Delta X_{\text{head}} = 5830136$	(from Eq 8.48)
$N_{y \text{ scan}} = 2$	(from Eq 8.99)	$\Delta Y_{\text{head}} = 5831000$	(from Eq 8.49)
$N_{\text{scan}} = 4$	(from Eq 8.47)		

Fig 45

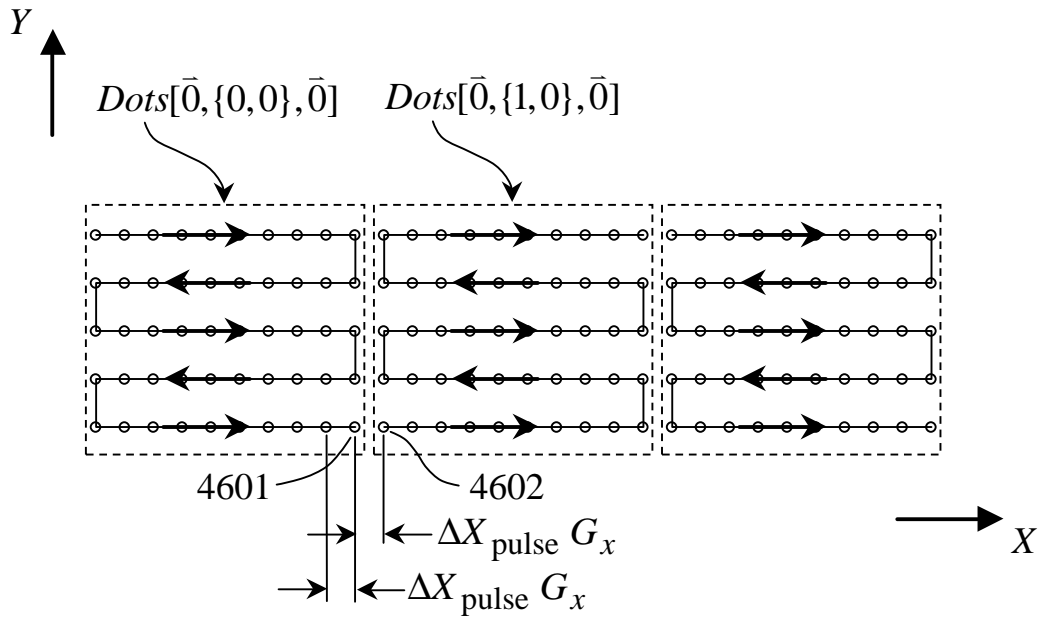

Fig 46A

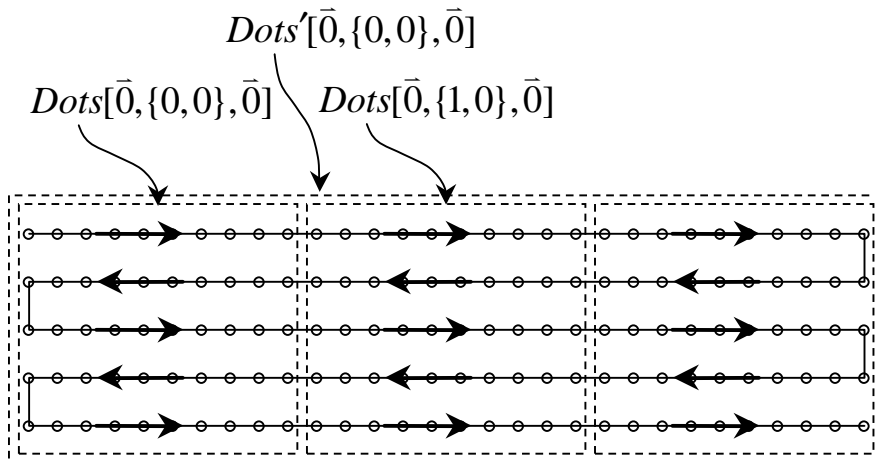

Fig 46B

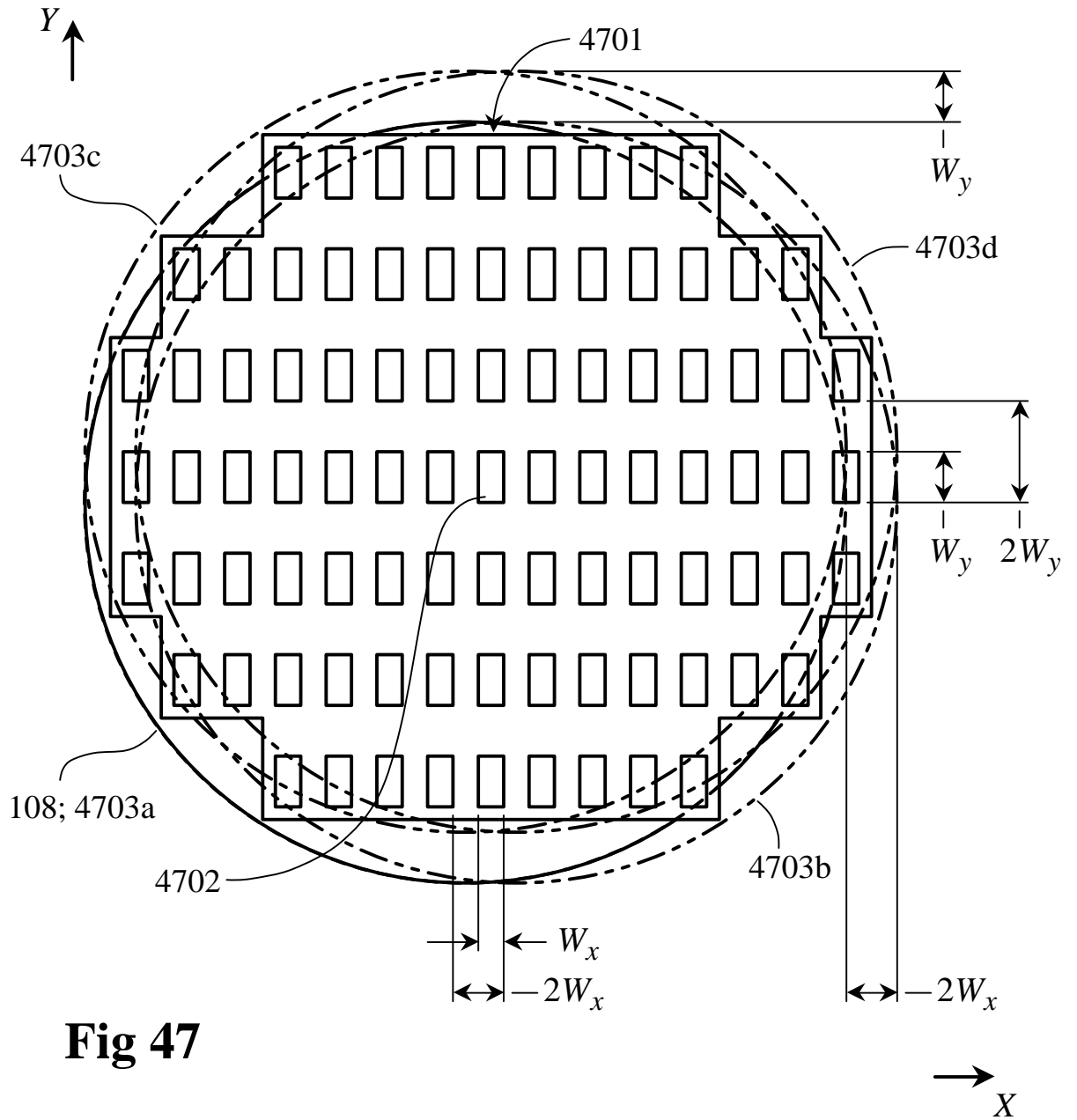

Fig 47

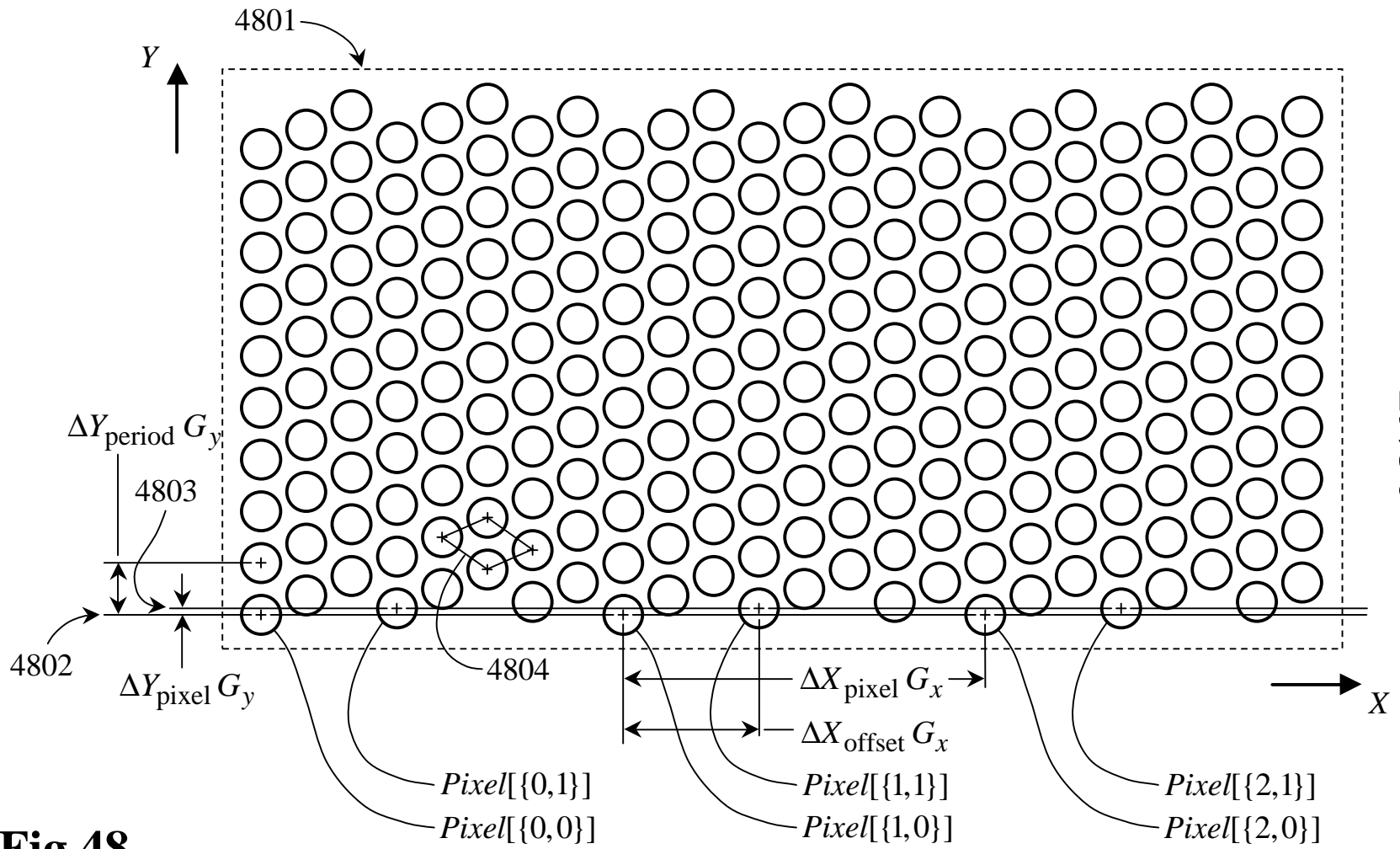
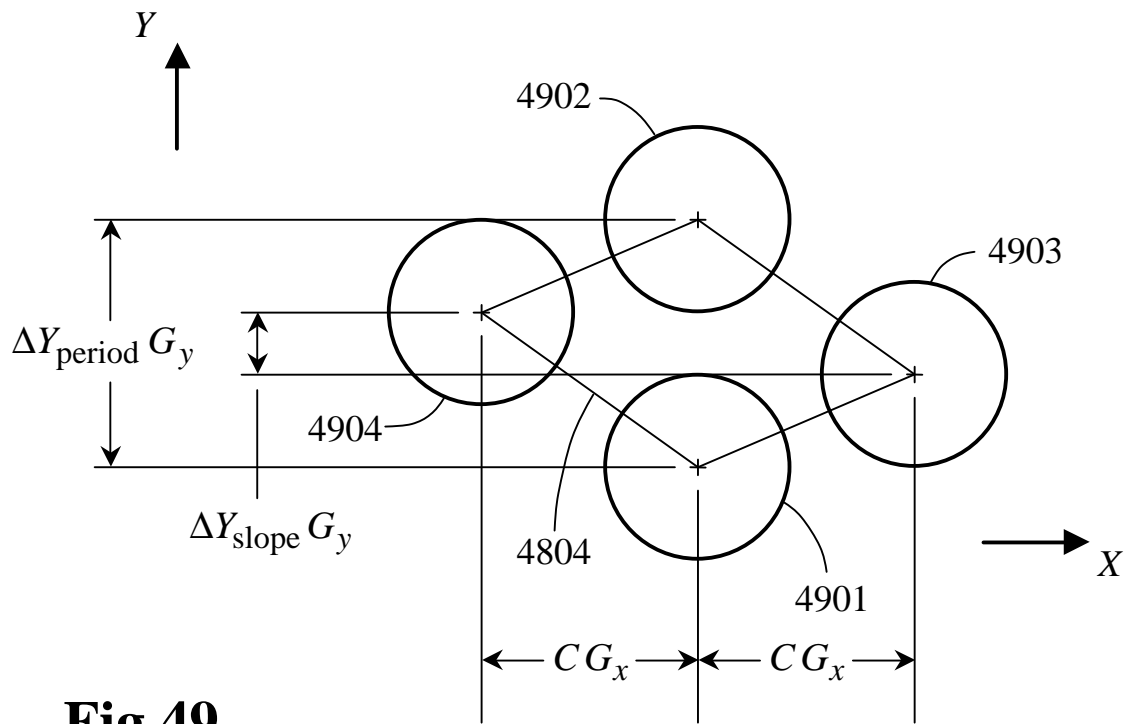

Fig 48

**Fig 49**

Scan parameters (wafer scan)

$W_x = 10 \text{ mm}$	(from Eq 8.118)	$\Delta X_{\text{pulse}} = 22$	(from Eq 8.138)
$W_y = 20 \text{ mm}$	(from Eq 8.119)	$\Delta Y_{\text{line}} = 23$	(from Eq 8.134)
$G_x = 6.866 \text{ nm}$	(from Eq 8.156)	$\Delta X'_{\text{scan}} = 2913108$	(from Eq 8.159)
$G_y = 6.860 \text{ nm}$	(from Eq 8.157)	$\Delta Y_{\text{scan}} = 230$	(from Eq 8.20))
$N'_{\text{pulse/line}} = 132414$	(from Eq 8.158)	$\Delta X_{\text{pixel}} = 66207$	(from Eq 8.145)
$N_{\text{line/scan}} = 10$	(from Eq 8.24)	$\Delta X_{\text{offset}} = 1522$	(from Eq 8.149)
$N'_{\text{pulse/scan}} = 1324140$	(from Eq 8.107)	$\Delta Y_{\text{pixel}} = 10$	(from Eq 8.133)
$N_{\text{pixel/row}} = 22$	(from Eq 8.153)	$\Delta Y_{\text{period}} = 870$	(from Eq 8.142)
$N_{\text{row/head}} = 291545$	(from Eq 8.155)	$\Delta X'_{\text{field}} = 2913108$	(from Eq 8.159)
$N_{\text{pixel/head}} = 6413990$	(from Eq 8.35)	$\Delta Y_{\text{field}} = 2915450$	(from Eq 8.40)
$N_{\text{row/period}} = 87$	(from Eq 8.141)	$\Delta X_{\text{stitch}} = 1456554$	(from Eq 8.116)
$N_{\text{period/head}} \cong 3351.1$	(from Eq 8.36)	$\Delta Y_{\text{stitch}} = 230$	(from Eq 8.42)
$N'_{x \text{ scan}} = 1$	(from Eq 8.109)	$\Delta X_{\text{head}} = 2913108$	(from Eq 8.159)
$N_{y \text{ scan}} = 2$	(from Eq 8.160)	$\Delta Y_{\text{head}} = 5830900$	(from Eq 8.49)

Fig 50

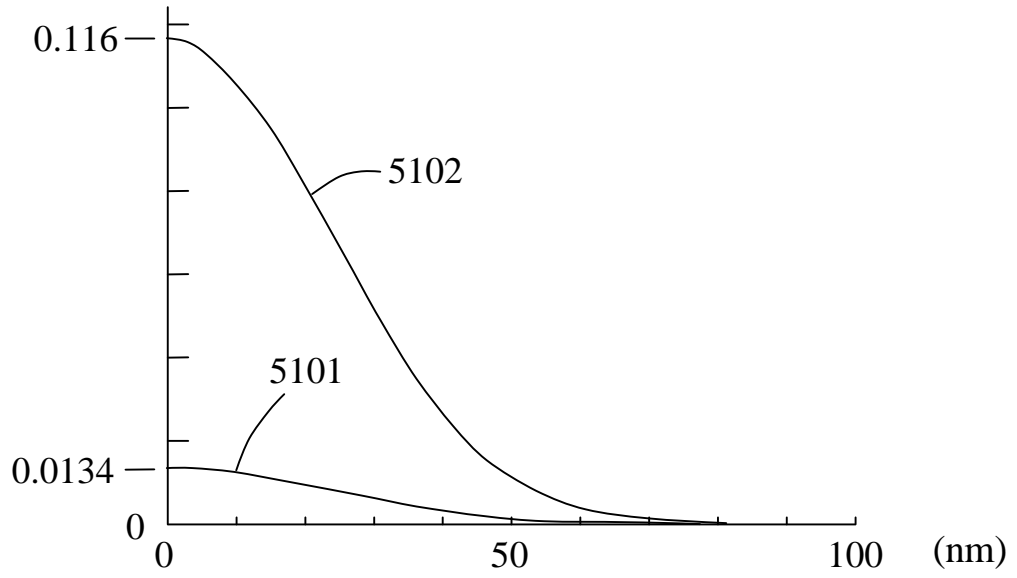

Fig 51

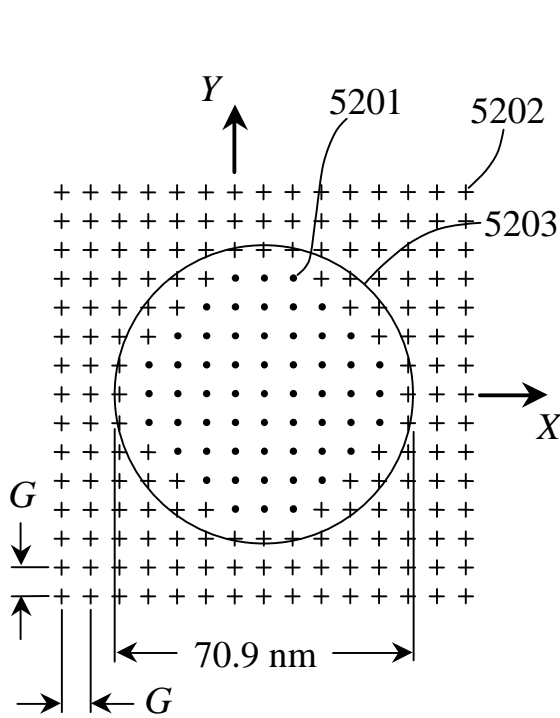

Fig 52

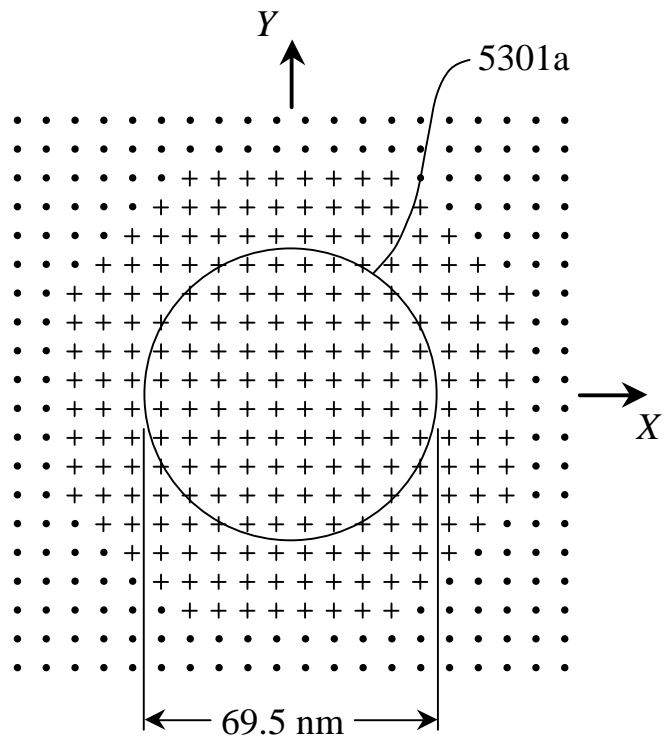

Fig 53

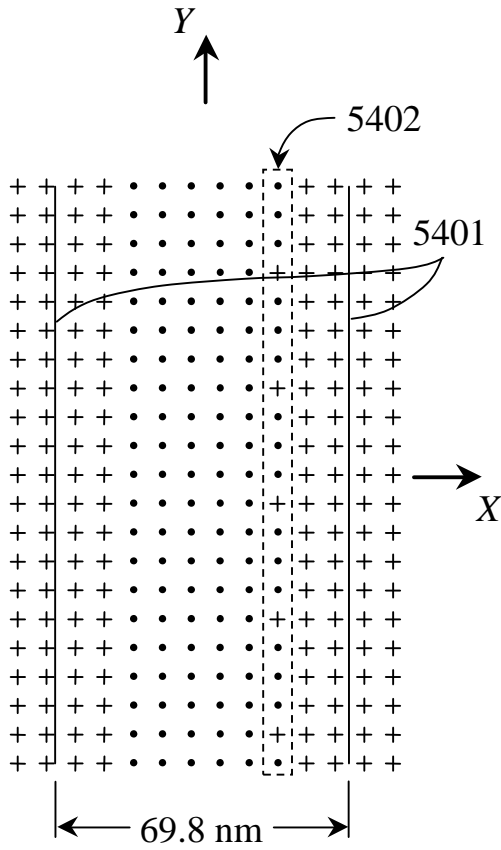

Fig 54

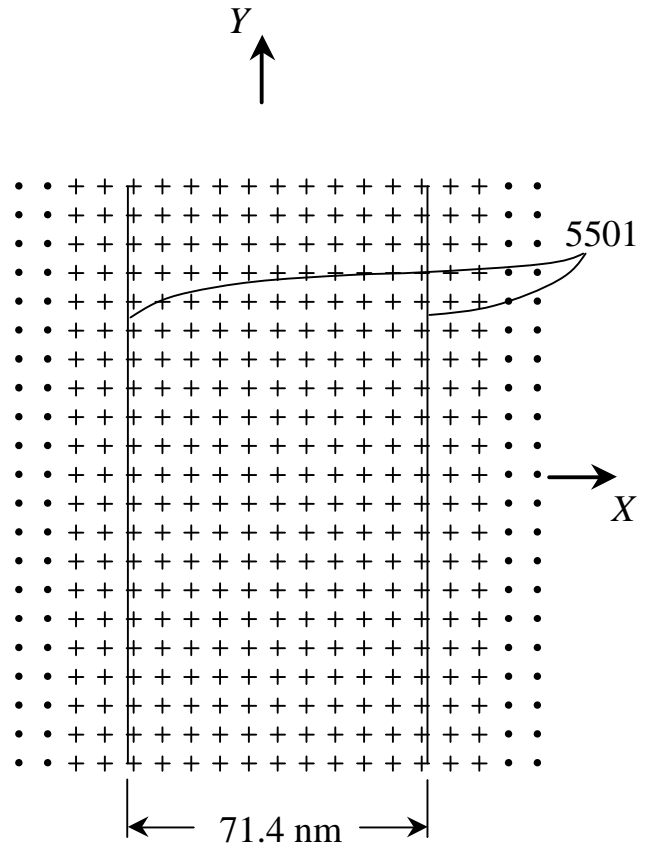

Fig 55

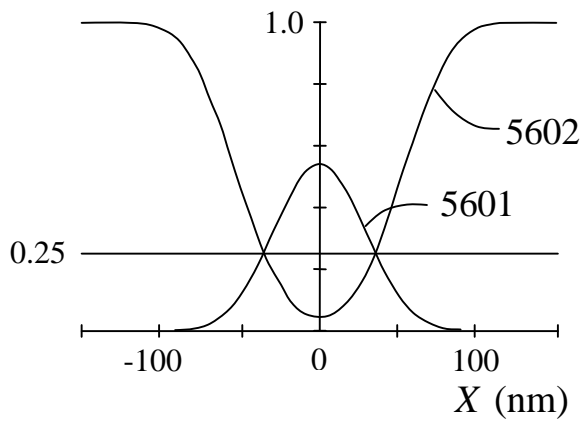

Fig 56

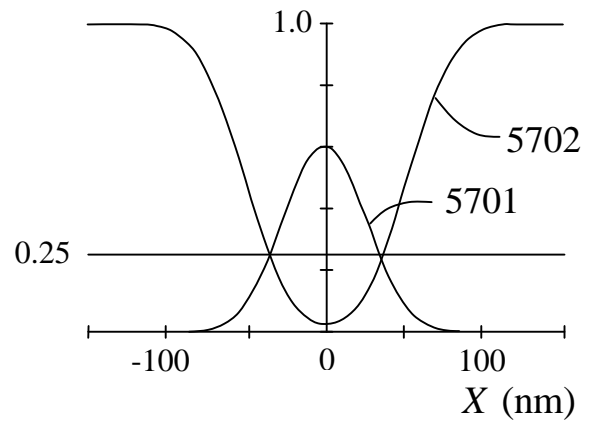

Fig 57

34/36

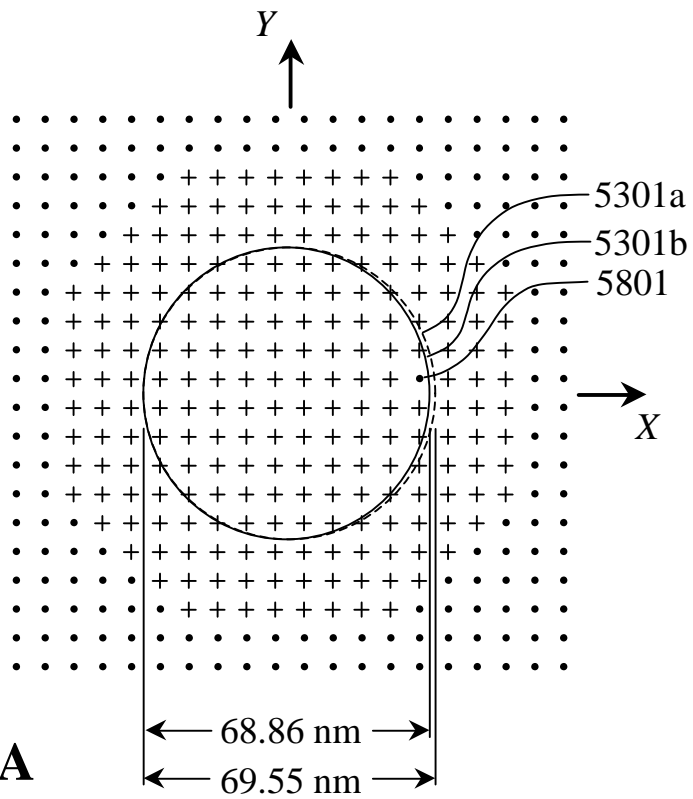

Fig 58A

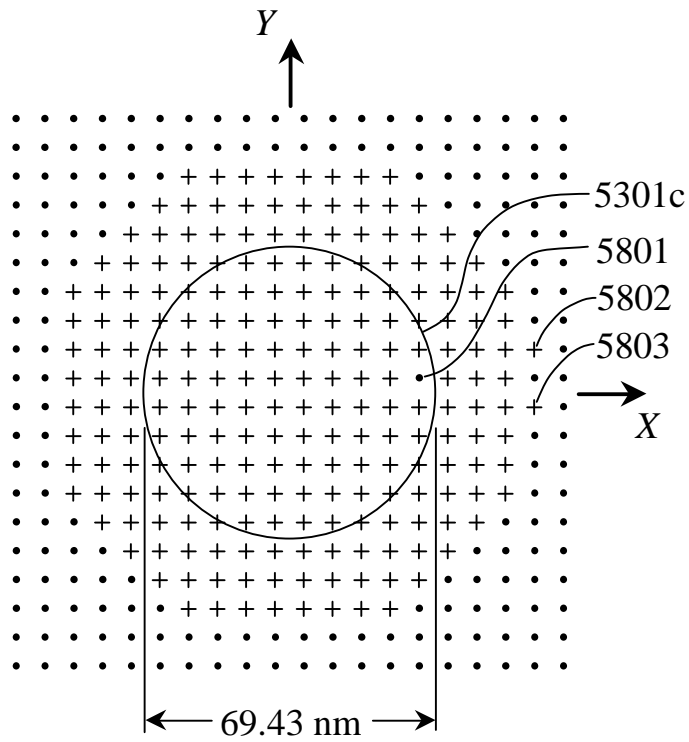

Fig 58B

35/36

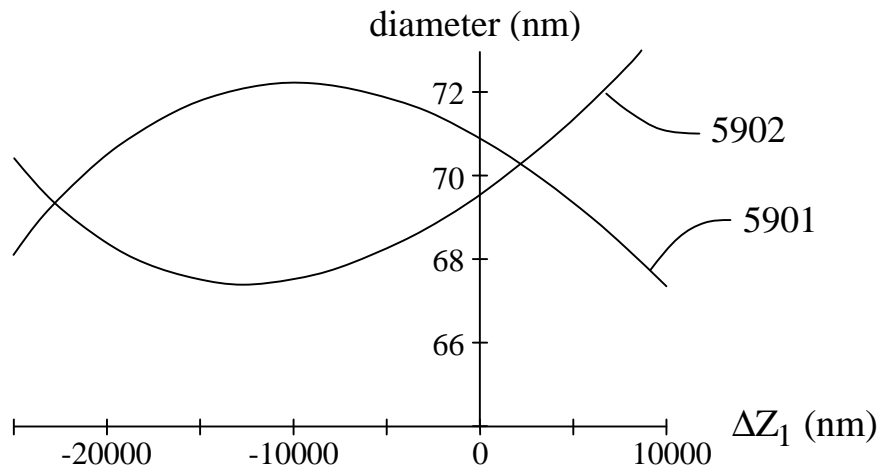

Fig 59

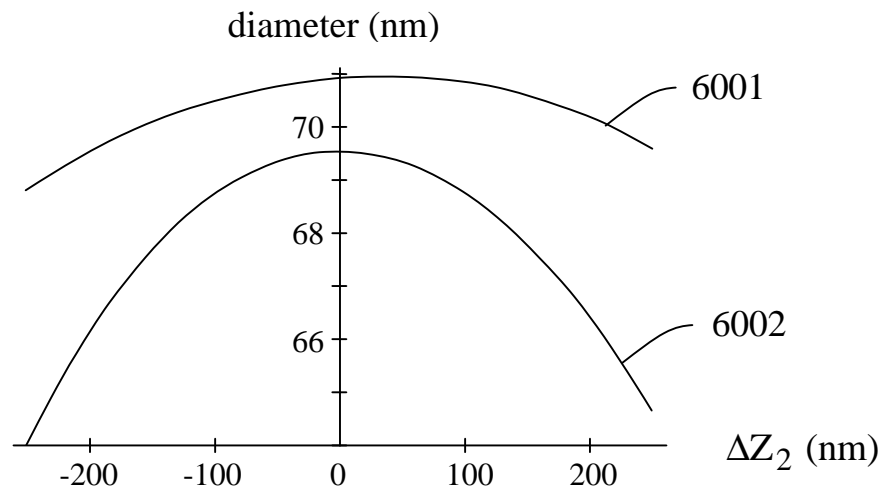

Fig 60

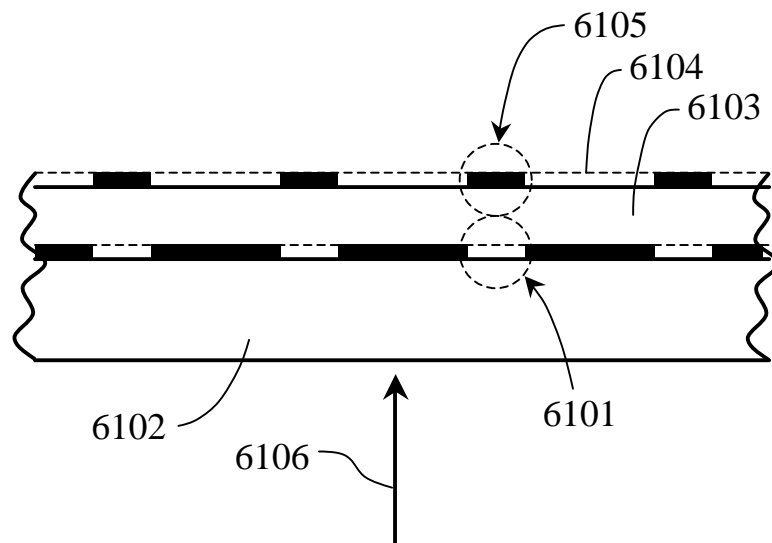

Fig 61

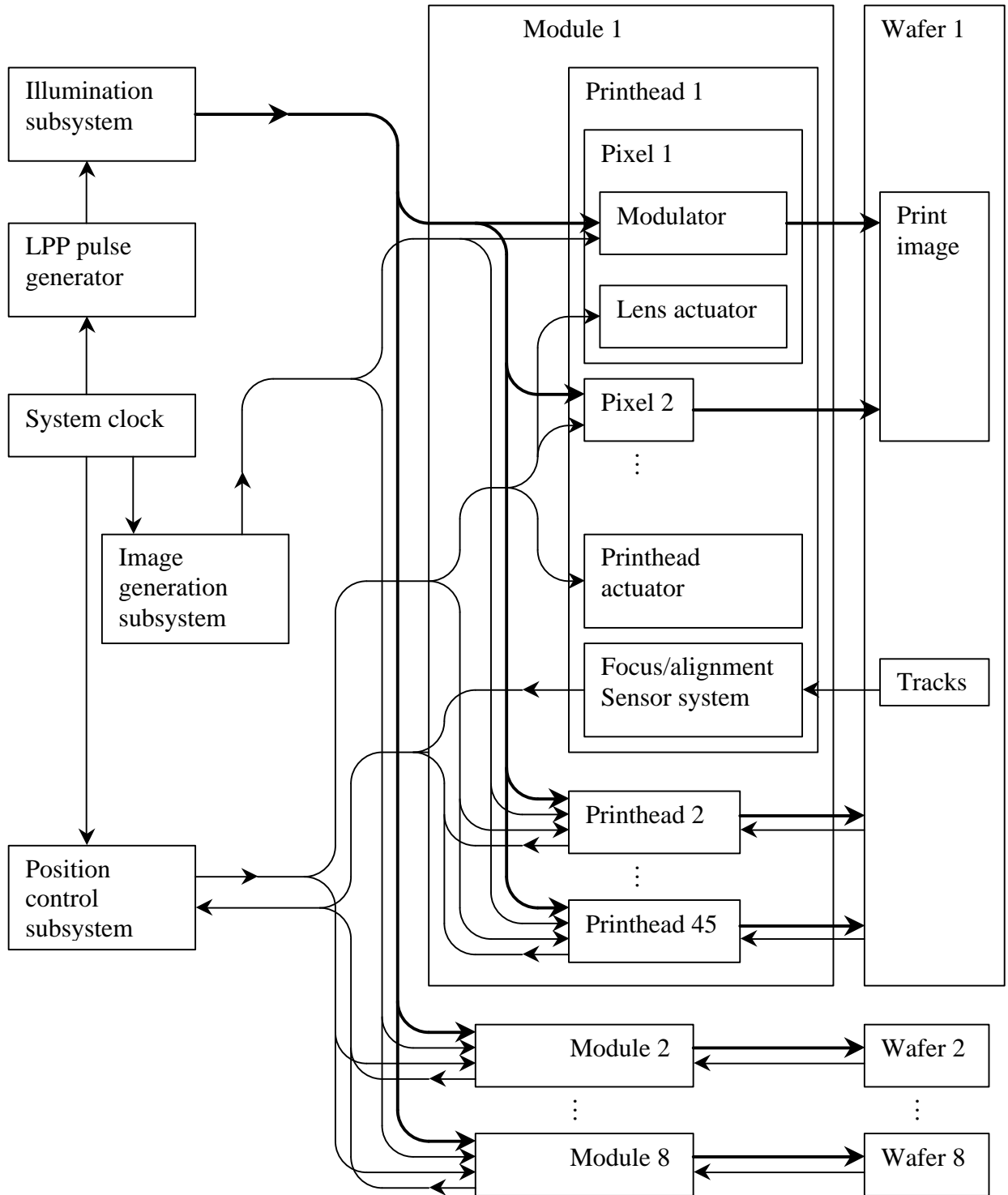

Fig 62